

# KC12 User Manual

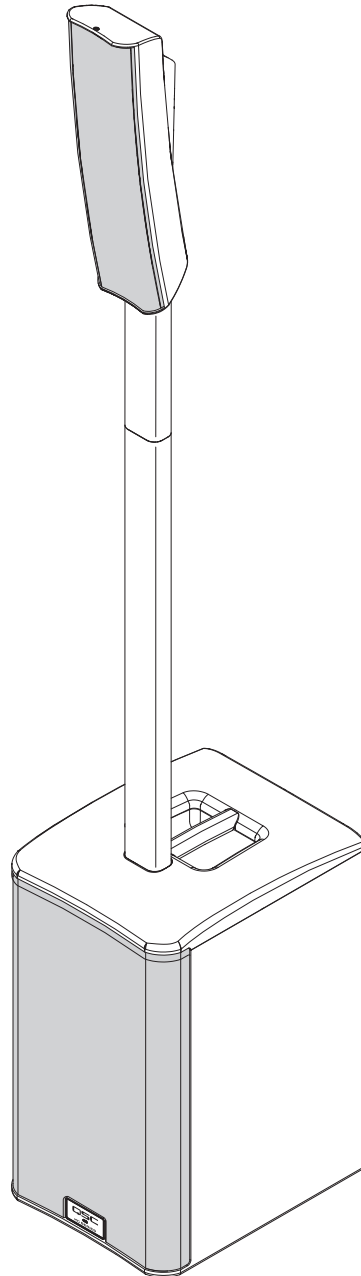

---

## KC12 Active 3-way Column Loudspeaker System



WA-001007-01-D



# Contents

Explanation Of Symbols . . . . .	4
Important Safety Instructions . . . . .	4
Regulatory Statements . . . . .	5
FCC . . . . .	5
Canada . . . . .	5
EU . . . . .	6
Brazil . . . . .	6
Taiwan . . . . .	6
Singapore . . . . .	7
Maintenance and Repair . . . . .	7
RoHS Statements . . . . .	7
Introduction . . . . .	8
Key Features and Technologies . . . . .	8
What's in the Box . . . . .	9
Package 1 Contents . . . . .	9
Package 2 Contents . . . . .	9
KC12 Features . . . . .	10
KC12S . . . . .	10
KC12T . . . . .	11
KC-SP32 . . . . .	11
KC12 Deployment . . . . .	12
Assembly . . . . .	12
Disassembly . . . . .	13
Deployment and Coverage . . . . .	14
System Power Sequencing . . . . .	14
Inputs . . . . .	15
Input A . . . . .	15
Input B . . . . .	15
Input C . . . . .	16
Outputs . . . . .	16
AC Mains . . . . .	17
AC Mains Disconnection . . . . .	17
Power Switch . . . . .	17
Cooling . . . . .	17

KC12 Menu .....	17
Display Introduction .....	17
Navigation Example .....	18
Menu Map .....	18
Menu Listing .....	18
Connecting Bluetooth Audio .....	22
Single Loudspeaker Pairing .....	22
Stereo and Multi Loudspeaker Pairing .....	22
Bluetooth Troubleshooting .....	23
Block Diagram .....	23
Hook Up Diagrams .....	24
KC12 connected to a DJ/FOH Mixer (Stereo) .....	24
KC12 connected to guitar/keyboard and microphone with self-monitoring (Mono) .....	24
KC12 connected to two microphones, BT playback source, and a recording out (Stereo) .....	25
KC12 connected with second KC12 as delay fill (Daisy Chained) .....	25
KC12 with external subwoofer .....	26
KC12 Specifications .....	27
Knowledge Base .....	28
Customer Support .....	28
Warranty .....	28
Manufacturer Information .....	28
EU Representative .....	28

## EXPLANATION OF SYMBOLS

The term “**WARNING!**” indicates instructions regarding personal safety. If the instructions are not followed, the result may be bodily injury or death.

The term “**CAUTION!**” indicates instructions regarding possible damage to physical equipment. If these instructions are not followed, it may result in damage to the equipment that may not be covered under the warranty.

The term “**IMPORTANT!**” indicates instructions or information that are vital to the successful completion of the procedure.

The term “**NOTE**” is used to indicate additional useful information.



**NOTE:** The intent of the lightning flash with arrowhead symbol in a triangle is to alert the user to the presence of un-insulated “dangerous” voltage within the product’s enclosure that may be of sufficient magnitude to constitute a risk of electric shock to humans.



**NOTE:** The intent of the exclamation point within an equilateral triangle is to alert the user to the presence of important safety, and operating and maintenance instructions in this manual.



### IMPORTANT SAFETY INSTRUCTIONS



**WARNING!:** TO PREVENT FIRE OR ELECTRIC SHOCK, DO NOT EXPOSE THIS EQUIPMENT TO RAIN OR MOISTURE.



**WARNING!:** While it is possible for one person to lift a KC12 loudspeaker, it is important to use proper lifting techniques. Suggested reading: OSHA Technical Manual on Back Disorders and Injuries. ([http://www.osha.gov/dts/osta/otm/otm\\_vii/otm\\_vii\\_1.html#app\\_vii:1\\_2](http://www.osha.gov/dts/osta/otm/otm_vii/otm_vii_1.html#app_vii:1_2)).

1. Read these instructions.
2. Keep these instructions.
3. Heed all warnings.
4. Follow all instructions.
5. Do not use this apparatus near water.
6. Clean only with a dry cloth.
7. Do not block any ventilation opening. Install in accordance with the manufacturer’s instructions.
8. Do not install near any heat sources such as radiators, heat registers, stoves, or other apparatus (including amplifiers) that produce heat.
9. Do not defeat the safety purpose of the polarized or grounding-type plug. A polarized plug has two blades with one wider than the other. A grounding type plug has two blades and a third grounding prong. The wide blade or the third prong are provided for your safety. If the provided plug does not fit into your outlet, consult an electrician for replacement of the obsolete outlet.
10. Protect the power cord from being walked on or pinched particularly at plugs, convenience receptacles, and the point where they exit from the apparatus.
11. Only use attachments/accessories specified by the manufacturer.
12. Unplug this apparatus during lightning storms or when unused for long periods of time.
13. Refer all servicing to qualified service personnel. Servicing is required when the apparatus has been damaged in any way, such as power-supply cord or plug is damaged, liquid has been spilled or objects have fallen into the apparatus, the apparatus has been exposed to rain or moisture, does not operate normally, or has been dropped.

14. The appliance coupler, or the AC Mains plug, is the AC mains disconnect device and shall remain readily operable after installation.
15. Adhere to all applicable, local codes.
16. To prevent electrical shock, the power cord shall be connected to a mains socket outlet with a protective earthing connection.
17. Consult a licensed, professional engineer when any doubt or questions arise regarding a physical equipment installation.
18. Do not use any aerosol spray, cleaner, disinfectant or fumigant on, near or into the apparatus. Clean only with a dry cloth.
19. Do not unplug the unit by pulling on the cord, use the plug.
20. Do not submerge the apparatus in water or liquids.
21. Keep ventilation opening free of dust or other matter.

## Regulatory Statements

### FCC

This device complies with Part 15 of the FCC Rules. Operation is subject to the following two conditions:

- (1) This device may not cause harmful interference.
- (2) This device must accept any interference received, including interference that may cause undesired operation.



**WARNING!** Changes or modifications not expressly approved by the party responsible for compliance could void the user's authority to operate the equipment.

**NOTE:** This equipment has been tested and found to comply with the limits for a Class A digital device, pursuant to part 15 of the FCC Rules.

These limits are designed to provide reasonable protection against harmful interference in a commercial environment. This equipment generates, uses, and can radiate radio frequency energy and, if not installed and used in accordance with the instruction manual, may cause harmful interference to radio communications. Operation of this equipment in a residential area is likely to cause harmful interference in which case the user will be required to correct the interference at his own expense.

This equipment complies with FCC radiation exposure limits set forth for an uncontrolled environment. This equipment should be installed and operated with a minimum distance of 20 cm (7.9 in) between the radiator and your body.

To access applicable FCC regulatory information on the equipment, navigate to Settings > Regulatory (see "KC12 Menu" on page 17).

### Canada

CAN ICES-003(A) / NMB-003(A)

This device complies with Industry Canada license-exempt RSS standard(s). Operation is subject to the following two conditions:

- (1) this device may not cause interference, and
- (2) this device must accept any interference, including interference that may cause undesired operation of the device.

This device has been evaluated and shown compliant with the RF exposure requirements listed in RSS-102 - Radio Frequency (RF) Exposure Compliance of Radio communication Apparatus limits under fixed exposure conditions (antennas are greater than 20 cm / 7.9 in from a person's body) when installed in certain specific OEM configurations.

To access applicable ICES regulatory information on the equipment, navigate to Settings > Regulatory (see "KC12 Menu" on page 17).

## EU

Hereby, QSC, LLC, declares that this device is in compliance with the following:

- European Restriction of Hazardous Substances (RoHS) Directive 2011/65/EC
- European Radio Equipment Directive (RED) 2014/53/EU

The full text of the EU declaration of conformity is available by visiting [www.qsc.com](http://www.qsc.com).

This product can be used in EU countries without any restrictions.



**WARNING!:** This device is designed for commercial use.

RF exposure assessment has been performed to prove that this unit will not generate harmful electro-magnetic emissions above the reference level as specified in EC Council Recommendation (1999/519/EC).

- Operating frequency range: 2402 to 2480 MHz
- Maximum RF output power: < 20 dBm E.I.R.P
- Temperature range: -20 to 50°C
- Software version: 1.0.57 or greater

To access installed software or firmware information on the equipment, refer to "KC12 Menu" on page 17.

### Disposal:



Do not dispose of this product with normal household waste at the end of its life cycle. Return it to a collection point for the recycling of electrical and electronic devices. This is indicated by the symbol on the product, user manual, or packaging. The materials are reusable according to their markings. By reusing, recycling, or other forms of utilization of old devices, you make an important contribution to the protection of our environment. Please contact your local authorities for details about collection points.

## Brazil

This product is approved by ANATEL, in accordance with the procedures regulated by Resolution No. 242/2000 and meets the technical requirements. This equipment is not entitled to protection against harmful interference and may not cause interference in duly authorized systems. For more information, see the ANATEL website – [www.anatel.gov.br](http://www.anatel.gov.br)



**WARNING!:** This device is designed for commercial use. The use and installation of the equipment must be carried out by trained personnel to avoid damage to the equipment or other hazards.

## Taiwan

According to the technical specifications for low-power radio frequency equipment:

For low-power radio frequency equipment that has obtained certification, no company, trader or user may change the frequency, increase the power, or change the characteristics and functions of the original design without approval. The use of low-power radio frequency equipment must not affect flight safety or interfere with legitimate communications; if interference is found, it should be stopped immediately and improved until there is no interference before continued use. The aforementioned legal communications refer to radio communications operated in accordance with the provisions of the Telecommunications Management Act. Low-power radio frequency equipment must endure interference from electromagnetic equipment that radiates electromagnetic waves for legitimate communications or industrial, scientific and medical purposes.

## Singapore

Complies with  
IMDA Standards  
DB104254

## Maintenance and Repair



**WARNING:** Advanced technology, e.g., the use of modern materials and powerful electronics, requires specially adapted maintenance and repair methods. To avoid a danger of subsequent damage to the apparatus, injuries to persons and/or the creation of additional safety hazards, all maintenance or repair work on the apparatus should be performed only by a QSC authorized service station or an authorized QSC International Distributor. QSC is not responsible for any injury, harm or related damages arising from any failure of the customer, owner or user of the apparatus to facilitate those repairs.

The KC12 does not contain user-serviceable parts. QSC does not recommend using chemicals or solvents to wash loudspeakers. Instead, use a damp towel with water only, and dry immediately after wiping down. Do not allow water to pool on the connectors, hardware, or rear user interface.

If exposed to direct sunlight for extended periods of time, the hardware and ABS parts may become discolored or faded. Cover or shade your KC12 loudspeakers from long-term, direct sunlight whenever possible.

Storage Temperature range: -20 C and +70 C, Relative Humidity range: 5 - 85% RH.

## RoHS Statements

The KC12 loudspeaker are in compliance with European RoHS Directive.

The KC12 loudspeaker are in compliance with "China RoHS" directives. The following table is provided for product use in China and its territories.

部件名称 (Part Name)	These products 这些产品					
	有害物质 (Hazardous Substances)					
	铅 (Pb)	汞 (Hg)	镉 (Cd)	六价铬 (Cr(vi))	多溴联苯 (PBB)	多溴二苯醚 (PBDE)
电路板组件 (PCB Assemblies)	X	○	○	○	○	○
机壳装配件 (Chassis Assemblies)	X	○	○	○	○	○

本表格依据 SJ/T 11364 的规定编制。(This table is prepared following the requirement of SJ/T 11364.)

○: 表示该有害物质在该部件所有均质材料中的含量均在 GB/T 26572 规定的限量要求以下。

○: Indicates that the concentration of the substance in all homogeneous materials of the part is below the relevant threshold specified in GB/T 26572.

X: 表示该有害物质至少在该部件的某一均质材料中的含量超出 GB/T 26572 规定的限量要求。

X: Indicates that the concentration of the substance in at least one of all homogeneous materials of the part is above the relevant threshold specified in GB/T 26572.

(目前由于技术或经济的原因暂时无法实现替代或减量) (Replacement and reduction of content cannot be achieved currently because of technical or economic reason.)

## Introduction





Building on the legacy of the World of K® portfolio, the KC12 is a 3-way, 3000-watt loudspeaker system encompassing the visual aesthetic of a column loudspeaker, while surpassing the acoustic performance of conventional designs. Simple and rapid to deploy, the elegant KC12, available in black and white, is ideal for solo entertainers, musicians and bands, mobile entertainers and DJs, AV productions and static installations.

## Key Features and Technologies

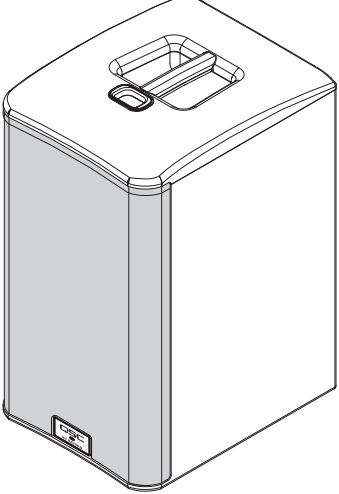
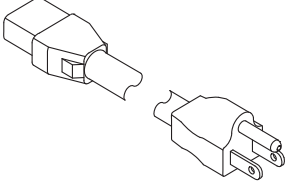

- 3-way loudspeaker system featuring a high-excursion 12-inch (305 mm) subwoofer, two high-excursion 4-inch (102 mm) midrange drivers and a 1-inch (25.4 mm) HF compression driver combined with the proprietary QSC LEAF™ waveguide.
- Very high, undistorted 132 dB maximum peak SPL.
- Energy-efficient Class D amplification featuring 3000 W of total peak power with Power Factor Correction and extremely low AC consumption.
- Innovative QSC LEAF™ (Length-Equalized Acoustic Flare) line-array waveguide provides defined, uniform coverage (145° H x 35° V) and excellent throw.
- Two combo XLR inputs (Line/Mic/Hi-Z and Line/Mic/+48 V), with independent, assignable Factory Presets for each input, perfect for small events where two microphones are needed for different use.
- Multi-function digital display for control and selection of loudspeaker functions including Global Parametric EQ, Subwoofer level, Presets and Scenes, Bluetooth® configuration, Room Delay (up to 200 ms), and Reverb.
- Bluetooth Audio featuring True Wireless Stereo (TWS), which ensures low-latency pairing between music source and both left and right loudspeakers, simultaneously.
- Configured with or without its column pole, the system is ideally suited for direct deployments on a floor, stage or riser with multiple available height options.
- QSC Acoustic Linear Phase (ALP) integration means that the KC12 can be paired seamlessly with external QSC subwoofers for additional low-frequency support when needed.
- Available in black and white finishes.

# What's in the Box

## Package 1 Contents

	<p>(1) KC12S Column System Subwoofer</p>		<p>(1) Locking AC Power cord</p>
	<p>(1) White QSC Logo Decal</p>		<p>(1) QSC Limited Warranty TD-000453</p>
	<p>(1) KC12 Quick Start Guide TD-001628</p>		<p>(1) Powered Loudspeaker Safety Sheet TD-000337</p>

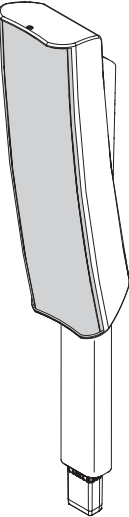
## Package 2 Contents

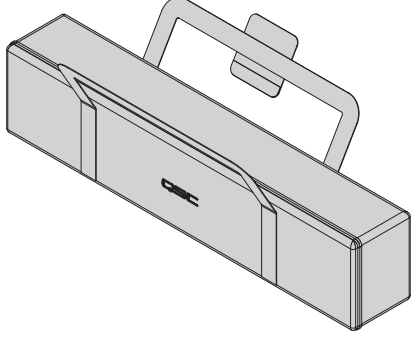
	<p>(1) KC12T Column System Loudspeaker</p>		<p>(1) KC-SP32 Column System Pole</p>		<p>(1) KC12-TOTE Padded Transport Tote</p>
---	--	---	---------------------------------------	---	--

# KC12 Features

## KC12S

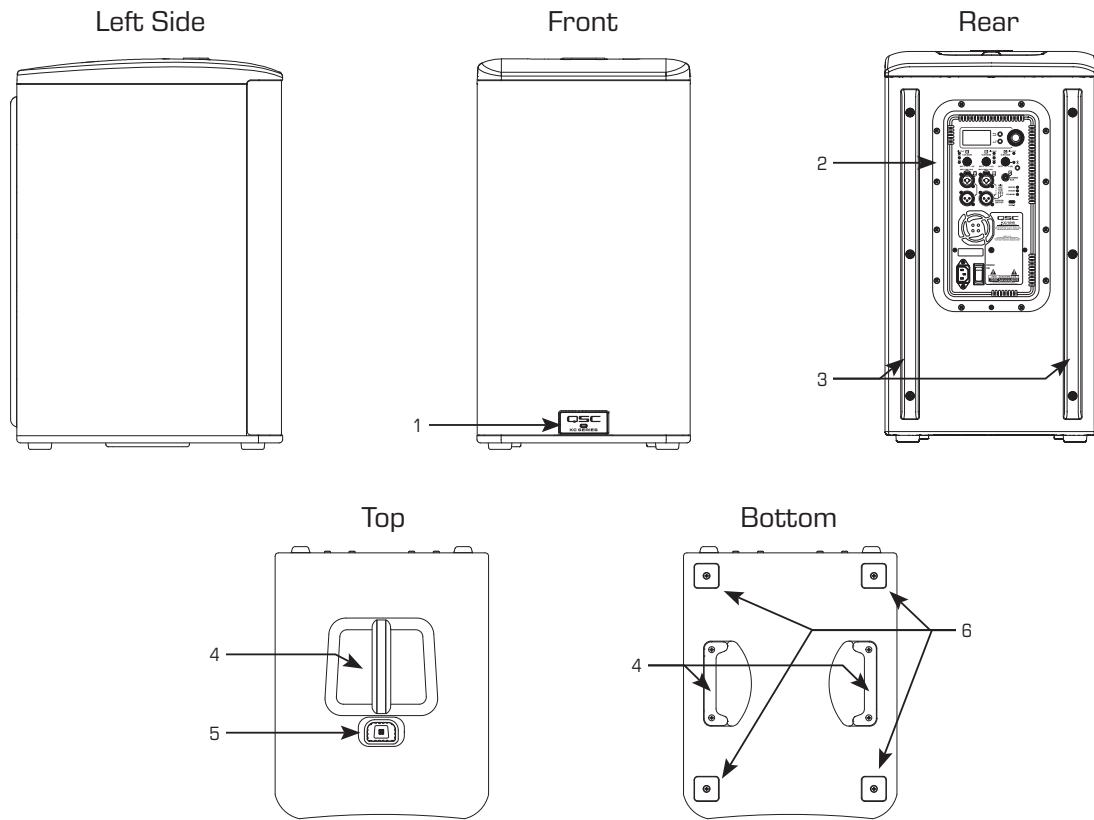

— Figure 1 —

1. Front power LED
2. Rear panel
3. Back bumpers
4. Carrying handles
5. Column system pole connector
6. Slip-resistant feet - four on the bottom

## KC12T

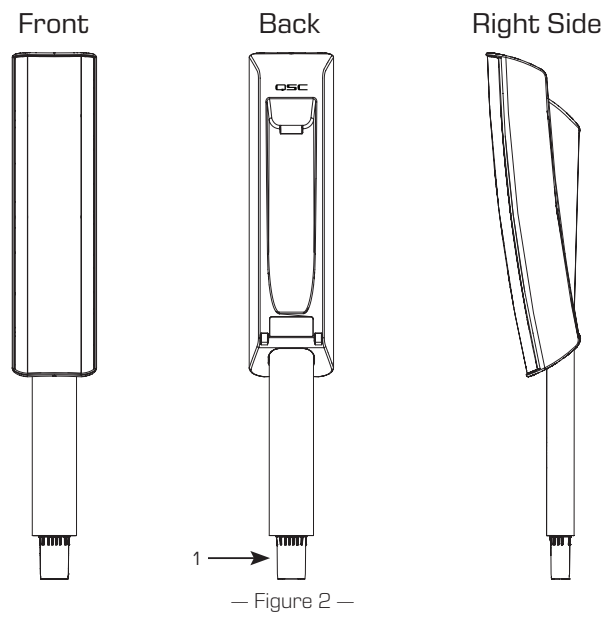

1. Column system pole connector

## KC-SP32

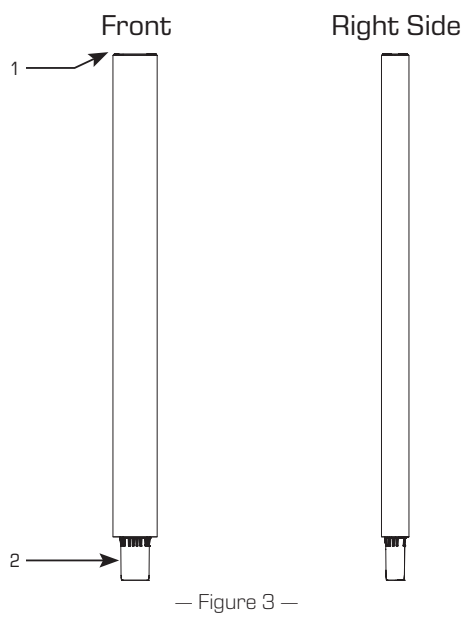

1. Column system pole connector (receiver)
2. Column system pole connector (coupler)

## KC12 Deployment

The KC12 is equipped with custom, high-durability and glass-fiber reinforced quick connectors that allow users to rapidly and safely deploy their system without any tools or external hardware needed. The top box loudspeaker (KC12T) and subwoofer (KC12S) can be deployed with or without the column pole (KC-SP32), depending on the application-specific coverage requirements. The KC12S subwoofer can also be used as a stand-alone subwoofer by utilizing "Sub Only" mode in the menu. (See "Menu Listing" on page 18 for more information.)



**CAUTION:** The KC12 should not be used in any kind of flown or horizontal configuration. Potential damage to the unit, or personal injury may occur.

## Assembly

1. Before placing the subwoofer (KC12S), ensure that the surface is level and structurally sound. The grille of the subwoofer will be in the same direction as the top box (KC12T once deployed), so deploy the sub with the grille pointed towards your audience area.
2. (Optional) Insert the coupler located on the bottom of the KC-SP32 into the top of the coupler receiver on the top of the KC12S (keeping hands, fingers or any other items clear of the coupler receiver), and press down firmly.
3. Insert the coupler located on the bottom of the KC12T top box loudspeaker into the coupler receiver on the top of the KC-SP32 or KC12S (depending on your deployment), and press down firmly.
4. Connect your AC and audio cables to the rear panel.

**NOTE:** The KC12 is intended for use with a maximum total system of one KC12T top box, one KC-SP32 column system pole, and one KC12S subwoofer in a single configuration.



**WARNING:** Keep hands, fingers, and any other items clear of the KC12 couplers and receivers when assembling the system, as personal injury may occur.



**WARNING:** Do not move your system when fully assembled. If you need to move your KC12, please disassemble the KC12T top box loudspeaker and KC-SP32 column pole and move the system, then repeat assembly instructions.



**WARNING:** Be careful to not get dust or water into the coupler sections of the KC12, as this can create potential connection issues for the system.

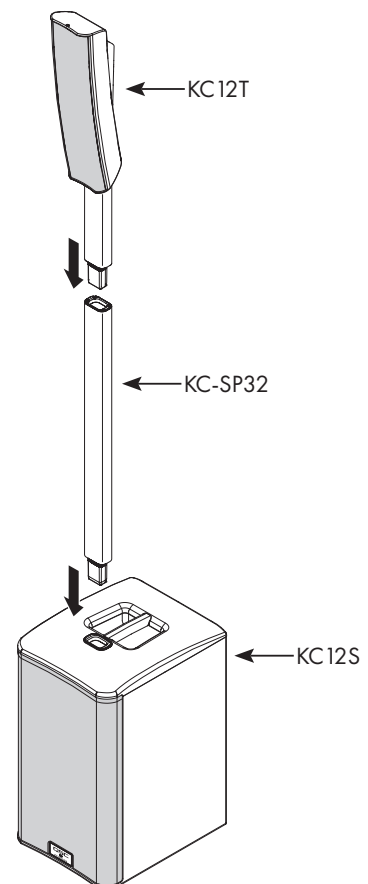

— Figure 4 —

## Disassembly

1. Use one hand to hold the KC-SP32 in place, and another to lift the KC12T top box loudspeaker out from the coupler receiver. It may be necessary to lightly wiggle.
  - a. Place the KC12T top box loudspeaker into the provided KC12-TOTE, with the grille facing towards the center of the tote, and the pole section of the top box resting against the angled foam spacer. See Figure 6.
2. Use one hand to hold the KC12S subwoofer in place, and another to lift the KC-SP32 column pole out from the coupler receiver.
  - a. Place the KC-SP32 column pole into the the provided KC12-TOTE, in the padded compartment area next to the KC12T top box loudspeaker, with the divider in between the KC12T and KC-SP32. See Figure 6.
3. Use the handle on the top of the KC12S subwoofer and the handles on the bottom of the subwoofer to transport to and from your deployment location.

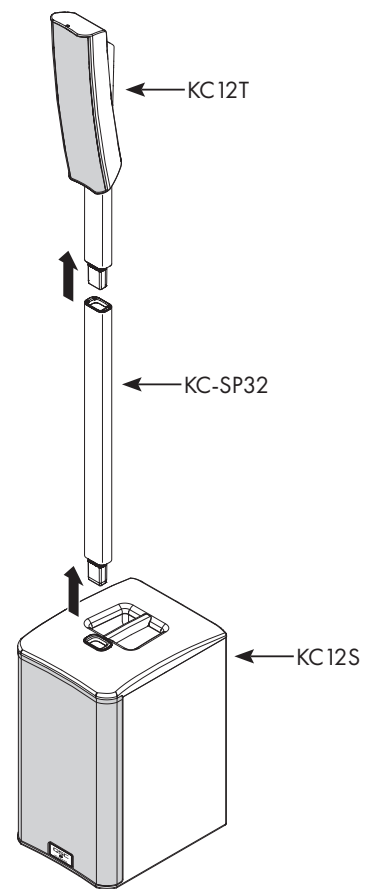

— Figure 5 —

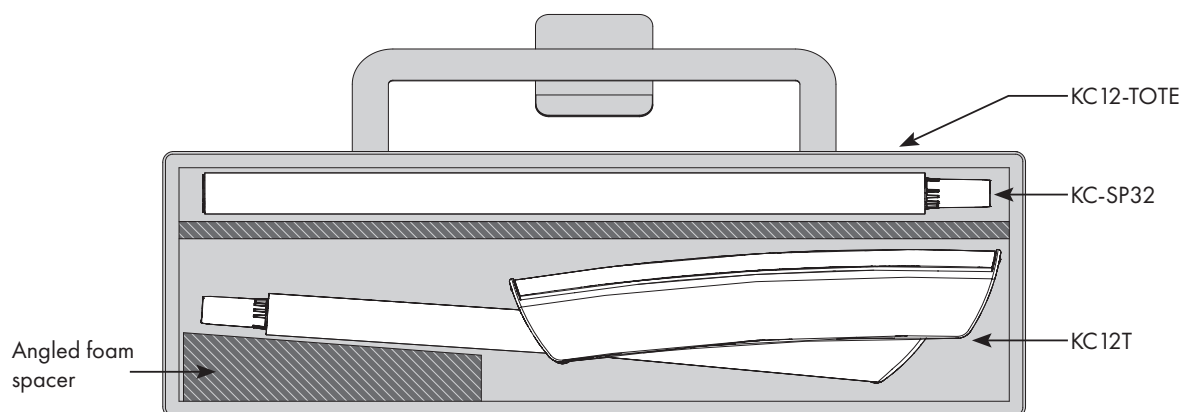

— Figure 6 —

## Deployment and Coverage

The QSC LEAF™ Waveguide optimized for the KC12 offers 35° of vertical coverage (+7.5° to -27.5°), and 145° of even horizontal coverage. This means that no matter where you place your KC12 Active Column Loudspeaker System, your audience will benefit from clean, even coverage throughout the listening area. The KC12 can be deployed:

- At full height on ground-level with both the KC-SP32 and KC12T for full acoustic throw across the head height of a standing audience
- At half-height, with just the KC12T for self-monitoring, lower-SPL applications, or seated audiences
- At half-height, on a stage/riser where space off the riser is at a premium or unavailable, and the loudspeaker resides at the audience head height

**NOTE:** Make sure to allow for at least 15 cm/6 inches of airflow at the rear of the KC12 Active Column Loudspeaker System in order to prevent premature thermal limiting due to airflow restriction.



**WARNING!** Do not use the KC-SP32 column pole as a device to lean on or brace yourself with. The connectors may become damaged, impacting the connectivity of the system



**WARNING!** Do not tip or lean the KC12 system once it has been assembled. This motion could damage the couplers or cause unintended harm to yourself or others nearby if the system were to tip over



**WARNING!** Do not install enclosures with their rear panels exposed to direct sunlight. Direct sunlight will heat the amplifier module and reduce its ability to produce full output. Install sunshades if needed. Maximum ambient temperature for full performance to specification is 50° C (122° F).



**WARNING!** Do not install enclosures where exposed to rain or other water sources. The enclosure is not weatherproof. Outdoor installations must provide protection from the elements.

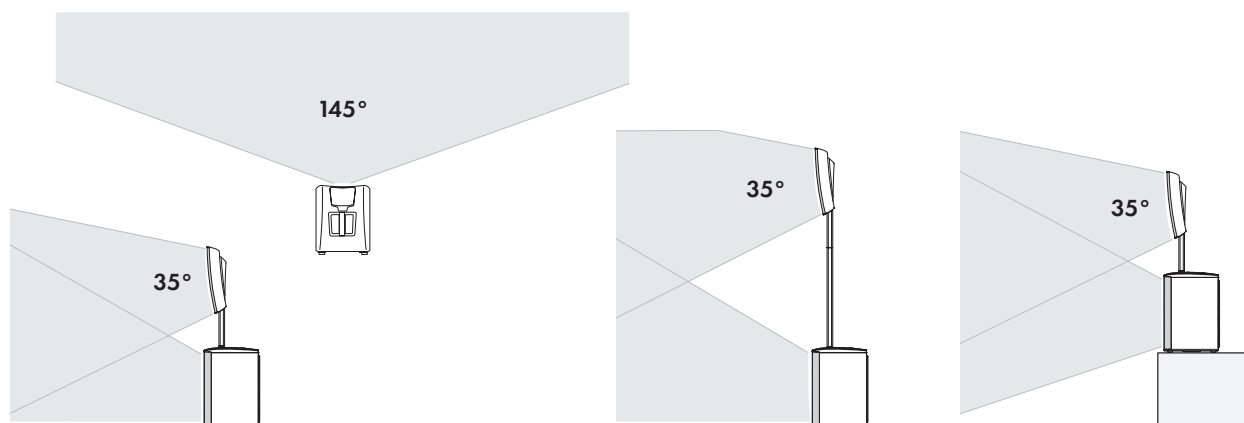

— Figure 7 —

## System Power Sequencing

Proper power turn on/turn off sequencing can help to prevent unexpected sounds from being produced by the system (pops, clicks, thumps). Always follow the rule that loudspeakers are "last on, first off".

**Power On Sequence:** Bring the output level control of the mixer (or other audio source) feeding your loudspeakers to its minimum position. Turn on all source devices (CD players, mixers, instruments), then turn on the KC12 Active Column Loudspeaker System. The level controls on your mixer may now be brought up.

**Power Off Sequence:** Turn off KC12 Active Column Loudspeaker Systems, then turn off all source devices. Any device being driven from the output of a KC12 via the THRU or ASSIGN OUTPUT should be turned off before the KC12 feeding it signal is powered off.

# Inputs

## Input A

- a. **SIG LED** – When illuminated **green**, it indicates a signal is present. When illuminated **red**, it indicates that the A/D converter is being clipped, and gain should be reduced until no longer flashing red. If this LED is not illuminated, the input signal is missing or too low to detect.
- b. **MIC LED** – When illuminated **amber** it indicates the input is configured to accept a microphone input. When not illuminated, it indicates the input is configured for a line-level input. You can change the setting through the Menu. When MIC is selected, the MIC Pre-amp is activated, and the **amber** MIC level LED illuminates. The MIC setting should only be used if a microphone is connected directly to the MIC/LINE input. Note that the input does not provide phantom power.
- c. **HI-Z LED** – When illuminated **yellow** it indicates the input is configured to accept a high impedance input, typically a musical instrument. When not illuminated, it indicates the input is configured for a line-level input. You can change the setting through the Menu. It is not recommended to activate Hi-Z mode without a 6.3 mm (1/4 inch) cable plugged into input A.
- d. **GAIN knob** – Sets the sensitivity of Input A which controls the signal level sent to the amplifier and the MIX OUT (POST DSP) output.
- e. **Combination XLR - 1/4 in. Jack connector** – Balanced XLR and 1/4" input. Accepts line-level, MIC-level, or HI-Z inputs. Select MIC, Line, or HI-Z through the Menu.

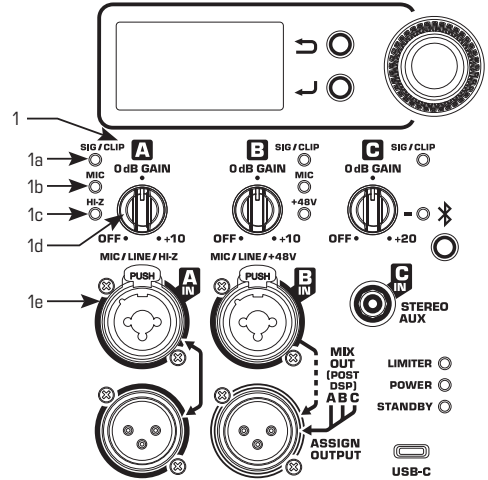

— Figure 8 —

## Input B

- a. **SIG LED** – When illuminated **green**, it indicates a signal is present. When illuminated **red**, it indicates that the A/D converter is being clipped, and gain should be reduced until no longer flashing red. If this LED is not illuminated, the input signal is missing or too low to detect.
- b. **MIC LED** – When illuminated **amber** it indicates the input is configured to accept a microphone input. When not illuminated, it indicates the input is configured for a line-level input. You can change the setting through the Menu. When MIC is selected, the MIC Pre-amp is activated, and the **amber** MIC level LED illuminates. The MIC setting should only be used if a microphone is connected directly to the MIC/LINE input. Note that this input can provide +48V phantom power. See next section for details.
- c. **+48V Phantom Power LED** – When illuminated **red** it indicates the input is sending +48V of phantom power to connected devices, typically condenser microphones or active DI boxes. When not illuminated, it indicates that phantom power is not present. You can change the setting through the Menu.

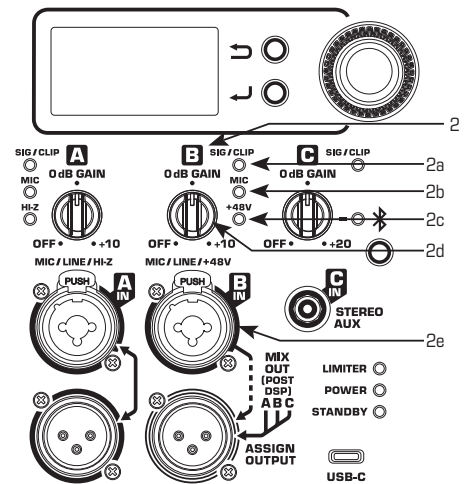

— Figure 9 —



**CAUTION!** Phantom Power can damage equipment if not supported.

- d. **GAIN knob** – Sets the sensitivity of Input B which controls the signal level sent to the amplifier and the MIX OUT (POST DSP) output.
- e. **Combination XLR - 1/4 in. Jack connector** – Balanced XLR and 1/4" input. Accepts line-level or MIC-level inputs. Select MIC or Line through the Menu.

## Input C

- SIG LED** – When illuminated **green**, it indicates a signal is present. When illuminated **red**, it indicates that the A/D converter is being clipped, and gain should be reduced until no longer flashing red. If this LED is not illuminated, the input signal is missing or too low to detect.
- GAIN knob** – Sets the sensitivity of Input C and Bluetooth which controls the signal level sent to the amplifier and the MIX OUT (POST DSP) output.
- Bluetooth LED** – This LED indicates the status of Bluetooth connection. When blinking rapidly, the Bluetooth module is searching for a host device. When the LED is solid **blue** the Bluetooth module is connected to a host device. If the LED is not illuminated, Bluetooth is not activated.
- Bluetooth button** – This button is used to activate/deactivate Bluetooth connectivity, and when short-pressed will navigate to the Bluetooth Menu. For instructions on how to utilize Bluetooth functionality, please see "Menu Listing" on page 18 of this manual.
- Stereo 3.5 mm (1/8 in) TRS connector** – Accepts line-level stereo input. Stereo input received at Input C is summed to mono.

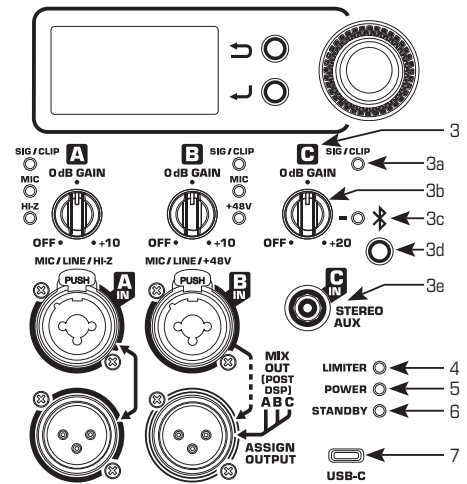

— Figure 10 —

- LIMITER LED** – Illuminates **red** when the built-in limiter is activated to protect and avoid damage to the amplifier or loudspeaker. If the signal level at any frequency is too high, or the amplifier is too hot, the limiter is activated and the LED is illuminated.
- POWER LED** – Illuminates **blue** when power is applied to the unit and the ON/OFF switch is in the ON position.
- STANDBY LED** – Illuminates **yellow** when STANDBY mode is activated. The KC12 is equipped with an automatic standby feature to conserve energy when the systems are not in use. If no signal is present on any input of a KC12 system the power amplifier will go into standby and the **yellow** STANDBY LED will illuminate. No other LEDs will illuminate when the unit is in standby; this includes both the Rear Power LED and the Front Power LED. In this mode, the amplifier will be powered down. A small amount of voltage will continue to flow from the AC power source into the power supply of the KC12 power module. This voltage will keep the power supply and DSP "awake" to reduce turn on time when the system is brought out of standby. The power up time of the amplifier is negligibly small and is shorter than the latency of the DSP, so no signal will be cut off when the KC12 system is brought out of standby. A KC12 loudspeaker can also be brought out of standby manually by turning the power switch off and then back on.
- USB-C 5V 3A connector** – For updating the firmware of the KC12 loudspeaker. See "Menu Listing" on page 18 to find where your firmware version is, and [www.qsc.com](http://www.qsc.com) for firmware updates. This port can also provide up to 5V 3A of power for charging a phone, tablet, or similar device.



**CAUTION:** 1) Do not plug a USB-C cable connected to an external charger into the USB-C port. The KC12 cannot be powered via this port, and attempting to do so may lead to damage to the product. 2) To avoid a computer acting as an external charger during a firmware update and subsequent damage to the KC12, you must power on the KC12 before connecting the USB cable and remove the USB cable from the KC12 before powering down the loudspeaker.

## Outputs

- OUTPUT A** is an Analog pass-through XLR that is hard-wired to Input A. The output signal is the same as the input signal on Channel A. Use this to daisy-chain loudspeakers with zero latency, or to share the Input A signal to other audio equipment.
- OUTPUT B** is a Post-DSP Assignable output XLR that outputs at +4 dBu. This can either be a digital pass-through for Input B, or a select-able digital mix of Channels A, B, C and Bluetooth. You can make multiple output assignments within the Display menu, however it will default to Mix Out.

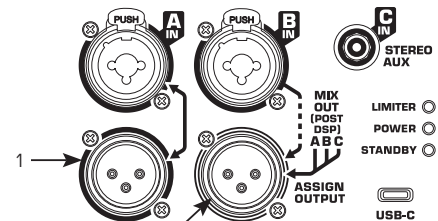

— Figure 11 —

**NOTE:** This line-level Output B signal is Post Gain, therefore any adjustments made to the input gain of any of the three channels will affect the output signal.

## AC Mains

Connect AC power to the IEC socket on the back of the amplifier by locating the IEC connector-end of the AC power cord and inserting it fully into the IEC inlet on the power amplifier module. NOTE: Turn off the AC power switch before connecting AC power.

The V-LOCK power cord has a special latching feature to prevent the power cord from being unintentionally removed. The IEC plug and socket are both blue in color so the power cord can be identified as a K Class loudspeaker cord. If the QSC supplied cord becomes lost or damaged, a standard replacement 18 gauge IEC power cord may be used. However, the latching system will only function with a V-LOCK power cord available from QSC, LLC.

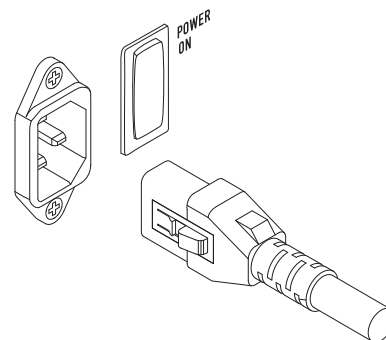

The KC12 is fed by a universal power supply. This power supply is capable of operating the system with input AC power voltages ranging from 100 - 240 VAC at 50 - 60 Hz.



**CAUTION!** Use only the power cable that is correct for your location.

## AC Mains Disconnection

Turn the AC power switch to the off position. To remove the AC mains cord, grasp the IEC connector's plastic body, press the yellow latch release button and pull, removing the connector from the socket.

## Power Switch

Push in on the top of the rocker switch to apply AC mains power to the powered loudspeaker. Push in on the bottom of the rocker switch to turn the powered loudspeaker off.

## Cooling

This is a powered loudspeaker containing an internal power amplifier that produces heat. Allow a minimum of 15 cm/6 inches of clearance at the rear or grille of the KC12S enclosure, and grille of the KC12T topbox enclosure, for convection cooling. Keep anything that might restrict airflow away from the rear or grille of the enclosures (i.e draperies, walls, etc.)

## KC12 Menu

The KC12 loudspeaker provide a multi-function digital display for control and selection of loudspeaker functions including presets, scenes, cross-over, EQ, delay and frequency contour.

## Display Introduction

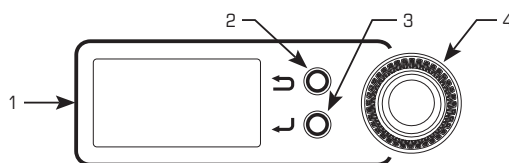

— Figure 12 —

1. **Home Screen:** Displays input types (MIC, Line, HI-Z, +48V) for channels A and B, and main functionality parameters. Light background with black text indicates the item is selected.
2. **Exit, or go back button:** press to return to the previous screen or menu level.
3. **Enter button:** confirm a selected parameter or open the selected menu item.
4. **Selector knob:** move to another menu item, or change a selected parameter.

## Navigation Example

To select a Preset:

1. Turn the Selector knob (4) clockwise to highlight the desired PRESET line.
2. Press the Enter button (3) to access the PRESET submenu.
3. Turn the Selector knob (4) clockwise or counterclockwise as needed to highlight the PRESET you wish to recall.
4. Press the Enter button (3) to recall the PRESET. A small triangle displays next to the recalled (active) PRESET.
5. Press the Exit button (2) to return to the Home screen.

## Menu Map

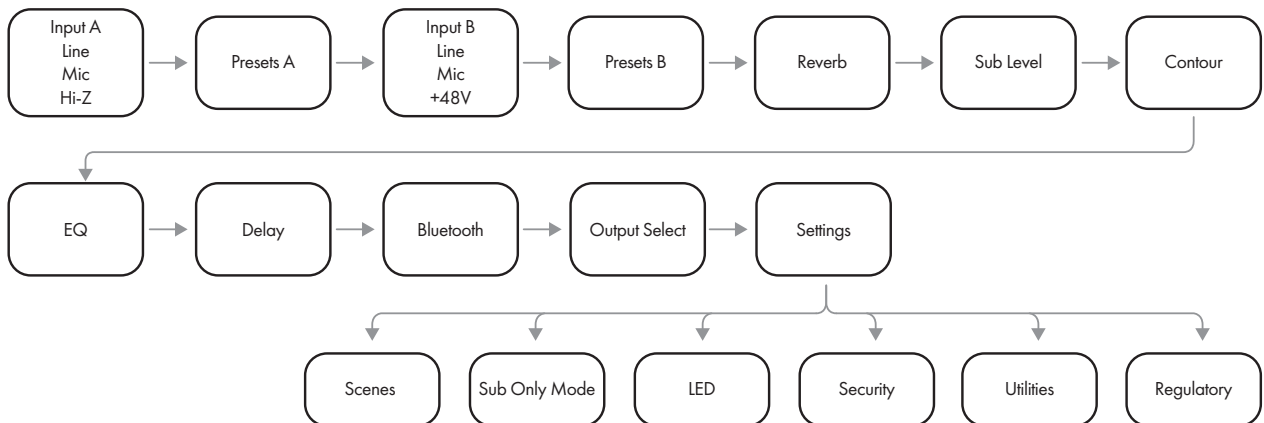

— Figure 13 —

## Menu Listing

### Home Screen

A: LINE	B: LINE
DEFAULT	DEFAULT
REVERB	OFF
SUB LEVEL	BOOST
CONTOUR	DEF

### INPUT A: Select the Sensitivity of Input A

- LINE – Use with mixers and other sources that have high-level outputs.
- MIC – Use with directly connected microphones and sources with low-level output.
- HI-Z – Use when connecting musical instruments with passive pick-up systems (for example, guitar, bass, etc).



### INPUT B: Select the Sensitivity of Input B

- LINE – Use with mixers and other sources that have high-level outputs.
- MIC – Use with directly connected microphones and sources with low-level output.
- +48V – Use when +48V Phantom Power is needed (for example, when connecting a condenser microphone or DI box)



**PRESETS (Inputs A and B):** Select a pre-programmed EQ and dynamic processing setting for specific applications.

- DEFAULT – No EQ or processing on the input
- VOX LO DYN – For lower-register performance vocals using a dynamic microphone
- VOX HI DYN – For higher-register performance vocals using a dynamic microphone
- VOX LO CON – For lower-register performance vocals using a condenser microphone
- VOX HI CON – For higher-register performance vocals using a condenser microphone
- HAND MIC – For speech intelligibility and feedback reduction using a hand-held microphone
- LAV MIC – For speech intelligibility and feedback reduction using a lavalier microphone
- HEAD MIC – For speech intelligibility and feedback reduction using a head microphone
- AC GUIT – For Acoustic Guitars with internal active or passive pickup systems
- E BASS – For bass instruments with active or passive pickup systems
- KEYS – For digital keyboards
- E DRUM – For electronic drum kits
- BAND MIC – For acoustic bands performing around a single condenser mic
- 100Hz HPF – For any input where a decrease in low-frequency is needed with a flat response

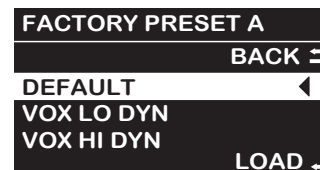

**REVERB LEVEL:** A single reverb is available with independent MIX controls available for both channels A and B.

- Reverb (IN or OUT) – Select IN to activate reverb using the selected settings. Select OUT to bypass the reverb settings and deactivate reverb.
- Reverb Mix (A and B) – The amount of reverb that can be added to the signal for both channels A and B, 1-30
- Reverb Size - Selectable SMALL, MEDIUM, LARGE. (Reverb size is the same for both channels A and B.)

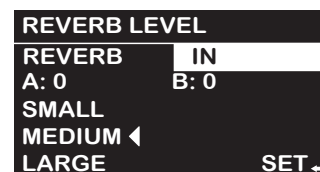

**SUB LEVEL:** Sets the subwoofer level, independent of the top box level. Using settings that increase the subwoofer level come with a trade-off of sensitivity, so you may see LIMITER indication at lower volume levels when used in the Balanced setting.

- BALANCED – The subwoofer is balanced with the top box for optimal output before limiting.
- BOOST increases the subwoofer level for improved low-frequency support with program material or electronic dance music.
- DEEP™ (Digital Extension and Excursion Processing) algorithm functions as a highly musical and non-distorting low-frequency EQ circuit that gives maximum subwoofer level without causing distortion or over-excursion.
- -1 to OFF – Allows the user to lower or turn off the subwoofer entirely if the application requires less low-frequency support.
- SUB ONLY – For use in subwoofer-only applications. This feature mutes the top box channel of the KC12 amplifier, so even with a top-box plugged in, there will be no sound produced from the top box.



**CONTOUR:** Set a pre-programmed EQ and dynamic processing setting for the entire loudspeaker.

- DEFAULT – The standard voicing of the loudspeaker
- LIVE – For live sound reinforcement and vocal clarity
- DANCE – Low and high frequency emphasis
- CINEMA – Enhanced low-frequency reinforcement for portable cinema applications

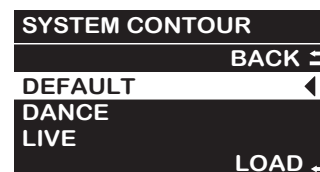

**EQ:** Adjust the 4-band, parametric equalizer.

- Use the scroll wheel to navigate a desired EQ band. Press the Enter button, and then use the Selector Knob to adjust. When you are finished, press the Enter button to make the change, or the Exit button to exit without changing the parameter.

EQ	dB	Hz	Q
HIGH	0.0	1.0K	0.7
EQ1	0.0	50.0	0.7
EQ2	0.0	200.0	0.7
LOW	0.0	100.0	0.7
EQ OUT	RESET		

	dB	Hz	Q
High Shelving Band (Default)	0.0 dB to -6.0 dB (0.0 dB)	1.0 kHz to 10.0 kHz (8 kHz)	N/A
EQ1 (EQ for Band 1) (Default)	0.0 dB to -6.0 dB (0.0dB)	50 Hz to 20.0 kHz (0.0 Hz)	0.4 to 4.0 (0.7)
EQ2 (EQ for Band 2) (Default)	0.0 dB to -6.0 dB (0.0 dB)	200 Hz to 20.0 kHz (0.0 Hz)	0.4 to 4.0 (0.7)
Low Shelving Band (Default)	0.0 dB to -6.0 dB (0.0 dB)	100 Hz to 500 Hz (0.0 Hz)	N/A

- EQ IN/OUT – Engages/bypasses the equalizer
- RESET – Returns the EQ to the default settings.

**ROOM DELAY:** Adjust the signal delay for rear fill and similar applications.

- 0 - 200 milliseconds, 0 - 226 feet , 0 - 68 meters
- All units of measure change together when the Selector knob is turned.

ROOM DELAY
0.0 MS
0.0 FEET
0.0 METERS

**BLUETOOTH MENU:** The menu for connecting Bluetooth-compatible devices and stereo pairing multiple KC12 loudspeakers. For steps on how to connect to a Bluetooth host device or True Wireless Stereo Pair multiple KC12 loudspeakers together, see "Connecting Bluetooth Audio" on page 22.

- STATUS – Displays "PAIR" if the KC12 loudspeaker is not connected, or "PAIRED" if connected to a host device. Status shows "SEARCHING" when pairing begins, and reverts to "PAIR" if no host device has been connected within 1 minute.
- STEREO – Displays "LINK" if the KC12 loudspeaker is not stereo-paired to a second KC12, or "LINKED" if connected to a second KC12 loudspeaker. Status shows "LINKING" when pairing begins, and reverts to "LINK" if no KC12 loudspeaker has been connected within 1 minute.
- ASSIGN – In STEREO mode, the Left and Right loudspeaker assignments can be toggled. In MULTI mode, you can assign either the LEFT or RIGHT channel of the Bluetooth stereo signal, or sum the stereo channels to MONO (default).
- UTILITIES – Additional options for Bluetooth functionalities. See next section for details.
- RESET – Resets all Bluetooth Menu settings to factory default and resets all host devices and stereo paired loudspeakers back to factory default state.
- DISCONNECT – Disconnects from the currently connected Bluetooth host device to allow the user to pair to another device.

BLUETOOTH
STATUS PAIR
STEREO LINK
ASSIGN MONO
UTILITIES ON
RESET DISCONNECT

**BLUETOOTH UTILITIES**

- SYNC TONE – Turns OFF or ON the sync tone played when the KC12 loudspeaker is connected to a Bluetooth audio source, or another KC12 when linked.
- LINK MODE – Two Bluetooth audio connection modes exist when pairing multiple KC12 loudspeakers together:
  - STEREO: True Wireless Stereo mode for Bluetooth, pairing a maximum of two KC12 loudspeakers together. Higher quality audio is provided using this STEREO mode.
  - MULTI: For Bluetooth pairing up to four (4) KC12 loudspeakers together.

UTILITIES
SYNC TONE: ON
LINK MODE: STEREO

**OUTPUT MENU:** ASSIGN OUTPUT B can be utilized as a customizable output, sending only the select-able channels to the output depending on your application needs.

**NOTE:** This output is post-DSP, so some latency will occur (<1 ms) from IN to THRU. For direct pass-THRU that is not affected by system processing, use Channel A IN and THRU.

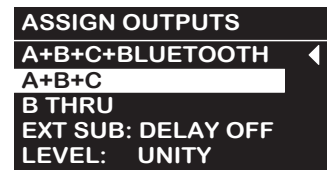

- A+B+C+BLUETOOTH – All channels are sent from the output (including Bluetooth), POST-DSP
- A+B+C – Channels A+B+C are sent from the output, but not Bluetooth, POST-DSP
- B-THRU – Channel B input signal is sent through, bypassing PRESETS and DSP
- EXT SUB – Applies system delay to time-align an external subwoofer that is immediately adjacent to the KC12 (<1 ms), allowing for optimal coupling.
- Output Level – Output level can be controlled independently to gain stage your system when connecting to loudspeakers, subwoofers, or mixers from this output.
  - -100 to +25 dB. Unity (0 dB) is default.

**NOTE:** When daisy-chaining a KC12 to another KC12 via the B ASSIGN OUTPUT, turn the GAIN KNOB of the receiving KC12 all the way to max level for correct gain staging.

**SETTINGS:** Additional functions of the loudspeaker

- **FIRMWARE VERSION** – The current firmware version and the factory default name of the loudspeaker are listed on the top bar of the settings menu. Users are unable to edit this field.
- **SCENES** – Specific settings of the loudspeaker (PRESETS, CONTOURS, SUB LEVEL DELAY, EQ, REVERB, OUTPUT) can be saved and recalled as a “SCENE”.
  - DEF – User can RECALL (only) the default Scene, which will factory restore all Scene-savable features.
  - SCENE 1 through 4 – User can SAVE and RECALL Scenes with unique user settings for commonly-used deployments
- **SUB ONLY MODE**
  - OFF (Default) – The KC12 can be operated as a full system that includes the KC12T top box.
  - ON – The KC12 MF/HF channel is muted.



SCENES		
DEF	SAVE	RECALL
1	SAVE	RECALL
2	SAVE	RECALL
3	SAVE	RECALL
4	SAVE	RECALL

**NOTE:** Do NOT operate the KC12S without the KC12T attached unless “SUB ONLY MODE” is ON within the Utilities menu. If the KC12S is operated without KC12T attached and “SUB ONLY MODE” is not ON, consistent audio output will not be possible.

- **LED** – Selects which combination of front and rear LEDs illuminate.
  - FRONT and REAR (default)
  - FRONT ONLY
  - REAR ONLY
- **SECURITY** – A 4-digit code can be entered to lock the loudspeaker settings from being adjusted, until the code is re-entered. To enter a code, use the Selector Knob to select a number, then press the ENTER button, and rotate the Selector Knob to the desired number (0-9). After a number has been chosen, press the ENTER button again, and repeat the process for the remaining 3 digits. After a code has been entered and the loudspeaker is locked, the user interface will return to the Home Screen, and a message will be displayed alerting the user that the unit is locked. When any button is pressed, the SECURITY screen will be displayed, and the user must follow the instructions above to re-enter the code to unlock the system.
  - FULL – The entire system is locked, and no functions (including GAIN) can be accessed or adjusted
  - PARTIAL – The system is locked and no functions can be accessed or adjusted, but GAIN knobs remain functional for Channel level adjustment

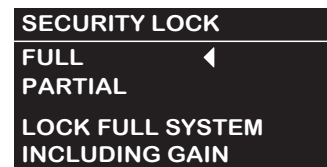
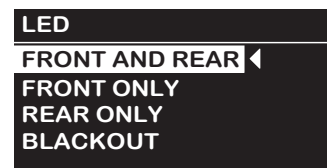

- **UTILITIES** – System Level Functions
  - **FACTORY RESET** – Restores all parameters to the factory defaults. This function is permanent and cannot be undone.
  - **TEST TONE** – A test tone from 20 Hz to 20 kHz will sweep through the system allowing the user to hear if all of the drivers are functioning properly. If you do not hear a tone in the subwoofer or top box, or if the sound is distorted, please contact QSC Service for assistance.
- **REGULATORY** – Statements for regional regulatory compliance.



## Connecting Bluetooth Audio

The KC12 Active Column Loudspeaker System utilizes a Bluetooth module that can be connected as a single playback unit, or with up to two (2) KC12 in STEREO Link Mode (True Wireless Stereo with higher audio quality,) or up to four (4) KC12 in MULTI Link Mode.

- Bluetooth Menu Quick Access – Short press of the Bluetooth button will take the user to the Bluetooth menu.

### Single Loudspeaker Pairing

- Long press 3+ seconds to engage the pairing mode. The Bluetooth LED will begin to indicate that the KC12 is looking for a source host device to pair with. When the loudspeaker is selected (from the host device) and a connection is made, the Bluetooth LED will become solid blue. If turned on, the Pairing Tone will play, also indicating a successful connection. (See "BLUETOOTH UTILITIES" on page 20 for Pairing Tone status).
  - If the loudspeaker is not paired to a host device after 1 minute of searching, Bluetooth turns off.
  - If the loudspeaker is paired to a host device and the Bluetooth button is held down for 3 seconds, the currently paired host device will disconnect (un-pairing tone will play if set to ON), and the loudspeaker will search for a new host device to pair with.

### Stereo and Multi Loudspeaker Pairing

- Step 1 – Navigate to the Bluetooth Utilities menu, and select STEREO for True Wireless Stereo pairing mode (Factory Default setting, two (2) KC12 loudspeakers maximum), or select MULTI for pairing up to four (4) KC12 loudspeakers together. This setting will remain in the last selected state, even if the unit is power cycled. Before linking, ensure all speakers are set to the same link mode (STEREO or MULTI).
- Step 2 – Begin with a single KC12 loudspeaker currently paired to your host device (see connection instructions above). If you are not already there, navigate to the Bluetooth menu with a short press on the Bluetooth button, or navigate to the Bluetooth Menu from the Main Menu with the Selector Knob, and press the ENTER button.
- Step 3 – From the KC12 Bluetooth menu of the first loudspeaker that is paired to the host device, use the Selector Knob to navigate to the selection that will either be labeled as STEREO or MULTI, depending on the LINK MODE set on the Bluetooth Utilities page. Press the ENTER button to begin the process of connecting the next KC12 loudspeaker.
- Step 4 – In each Bluetooth Menu of the other KC12 loudspeakers, use the Selector Knob to navigate to the STEREO or MULTI field and press the ENTER button to confirm. Perform this task for one additional KC12 if you are set to STEREO Link, and up to 3 additional KC12s if you are set to MULTI Link.
- Step 5 – When a Link connection is made, a pairing tone plays through each loudspeaker.
  - » Each loudspeaker (once connected in MULTI Link Mode) can be set to either LEFT, RIGHT, or MONO from the Bluetooth Menu (Default is MONO). In STEREO Link Mode, the loudspeakers can only be set to either LEFT or RIGHT.
  - » If a host device is un-paired from the Bluetooth connection, an un-pairing tone is played through the loudspeaker to notify the user of a connection status change.

**NOTE:** You cannot connect two or more loudspeakers in either STEREO or MULTI Link Mode unless a host device is already paired to your first KC12 loudspeaker.

- Bluetooth Power Off – Long press the Bluetooth button on the loudspeaker for 5+ seconds to un-pair the host device and turn Bluetooth off. If other KC12 loudspeakers were previously connected (Stereo or Multicast), all remaining KC12 loudspeakers connected to the host device will return to MONO Bluetooth audio. An un-pairing tone plays through the loudspeaker when the host device is un-paired.

## Bluetooth Troubleshooting

In the instance that your host device cannot find the KC12 loudspeaker when attempting to PAIR or is having trouble re-connecting, turn the Bluetooth function in your host device off and then back on again. Navigate to BLUETOOTH menu > RESET and clear all connections by pressing the ENTER button. Power the KC12 off and back on again. Repeat the connection process again from Step 1.

## Block Diagram

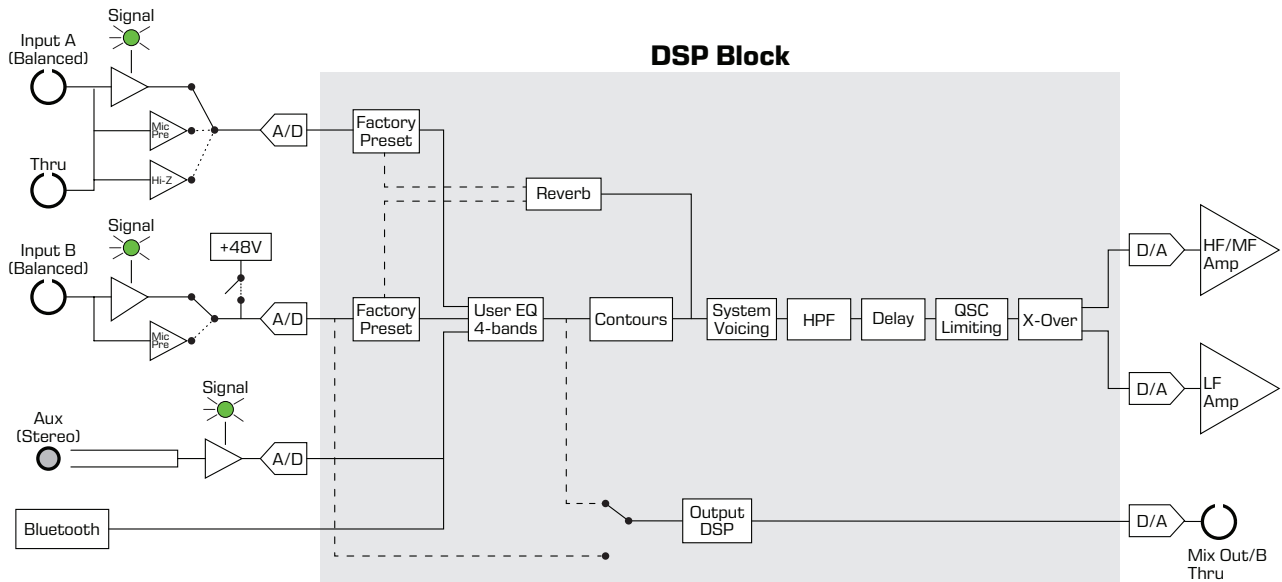

— Figure 14 —

# Hook Up Diagrams

## KC12 connected to a DJ/FOH Mixer (Stereo)

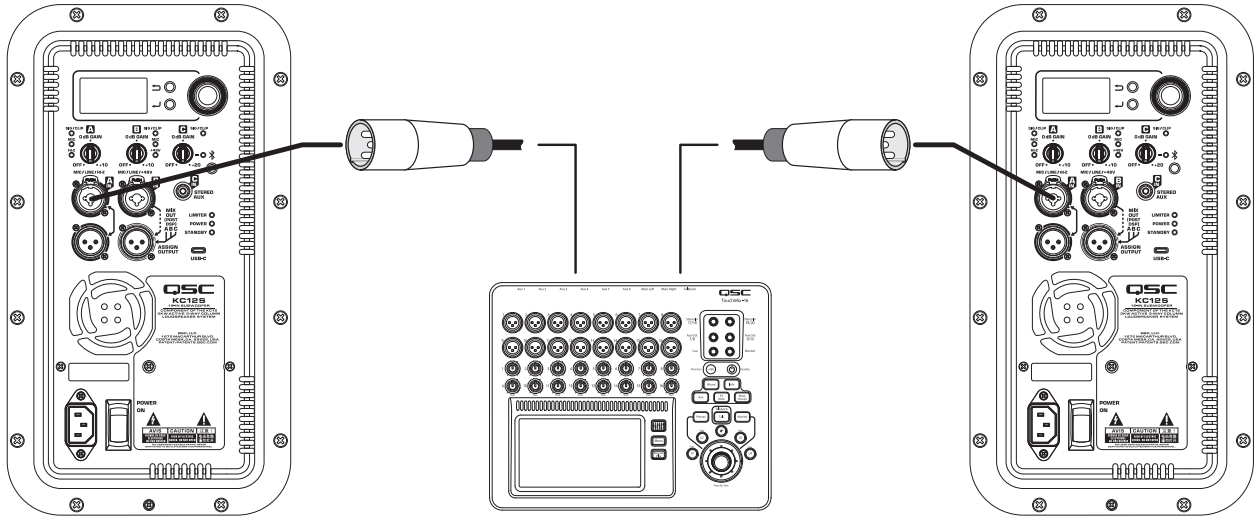

— Figure 15 —

## KC12 connected to guitar/keyboard and microphone with self-monitoring (Mono)

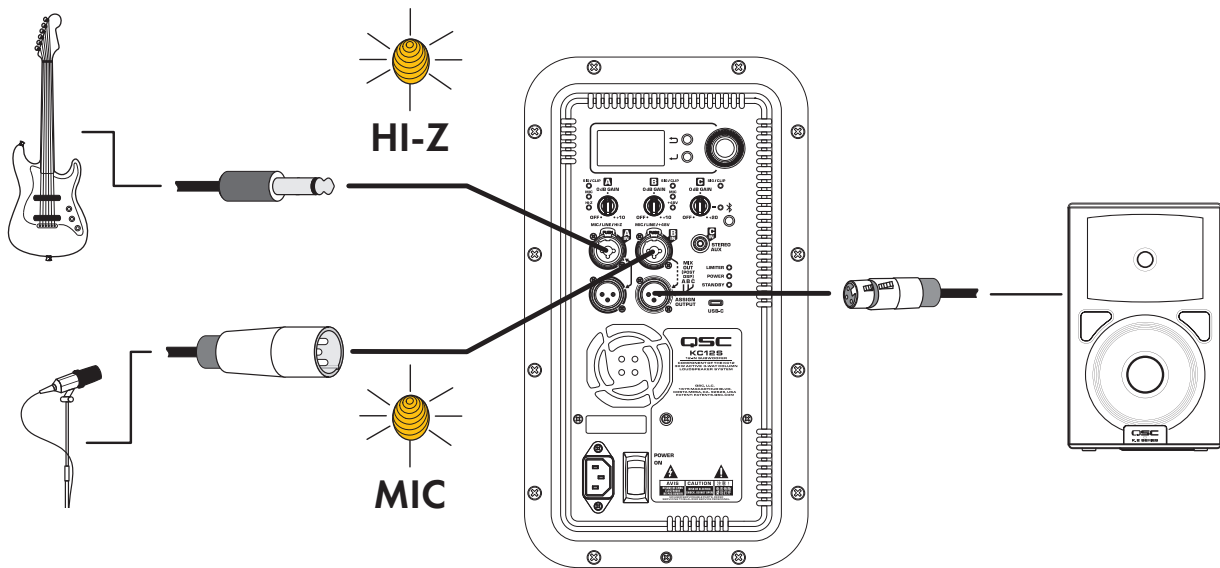

— Figure 16 —

KC12 connected to two microphones, BT playback source, and a recording out (Stereo)

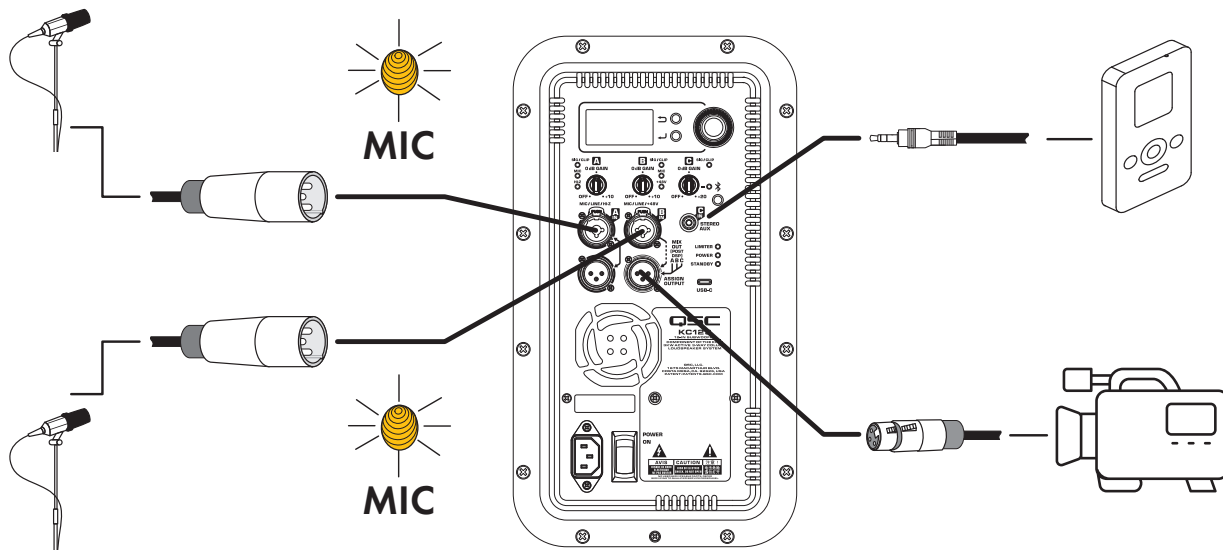

— Figure 17 —

KC12 connected with second KC12 as delay fill (Daisy Chained)

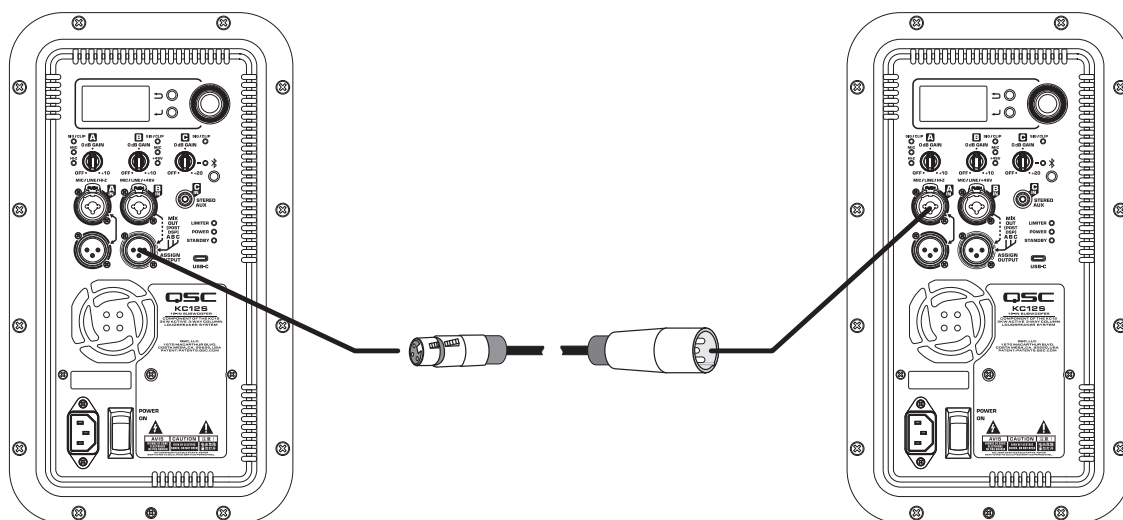

— Figure 18 —

KC12 with external subwoofer

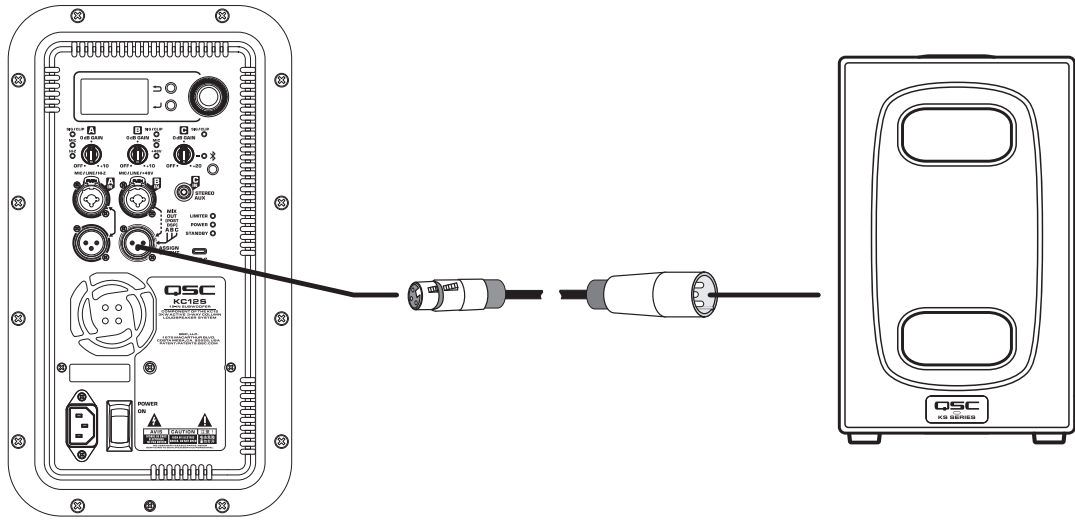

— Figure 19 —

# KC12 Specifications

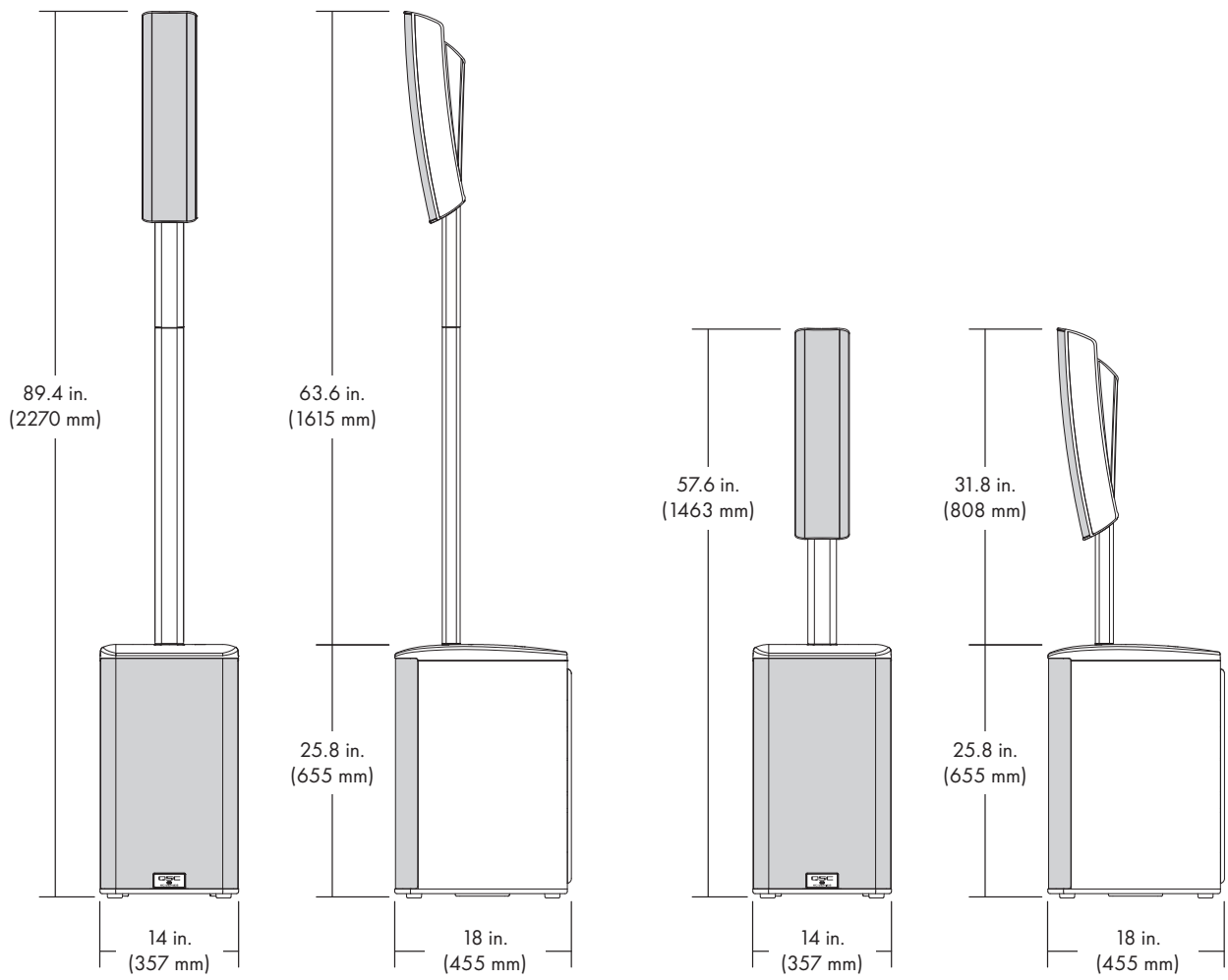



## Knowledge Base

Find answers to common questions, troubleshooting information, tips, and application notes. Link to support policies and resources, including software and firmware, product documents, and training videos. Create support cases.  
[support.qsc.com](https://support.qsc.com)

## Customer Support

Refer to the Contact Us page on the QSC website for Technical Support and Customer Care, including their phone numbers and hours of operation.  
[qsc.com/contact-us/](https://qsc.com/contact-us/)

## Warranty

For a copy of the QSC Limited Warranty, go to:  
[qsc.com/support/warranty-statement/](https://qsc.com/support/warranty-statement/)

## Manufacturer Information

QSC, LLC  
1675 MacArthur Blvd. Costa Mesa, CA 92626, USA

## EU Representative

QSC EMEA GmbH  
Am Ilvesbach 6, 74889 Sinsheim, Germany  
[www.qsc.com](https://www.qsc.com)

© 2025 QSC, LLC. All Rights Reserved.

QSC, LLC's trademarks include but are not limited to QSC® and all trademarks are listed under [www.qsc.com/trademarks](https://www.qsc.com/trademarks), some of which are registered in the U.S. and/or other countries.